

**FITTING INSTRUCTIONS - NOTICE DE POSE - MONTAGE HANDLEIDING - MONTAGEANLEITUNG
ISTRUZIONI DI MONTAGGIO - INSTUCCIONES DE MONTAJE**

Warranty. This product is covered by a 10 year manufacturer's warranty. Please see the P C Henderson website for terms and conditions.

WATCH THE INSTALLATION VIDEO

Visit: www.pchenderson.com/rustic-installation

Or scan the QR code using your phone



Tools Required

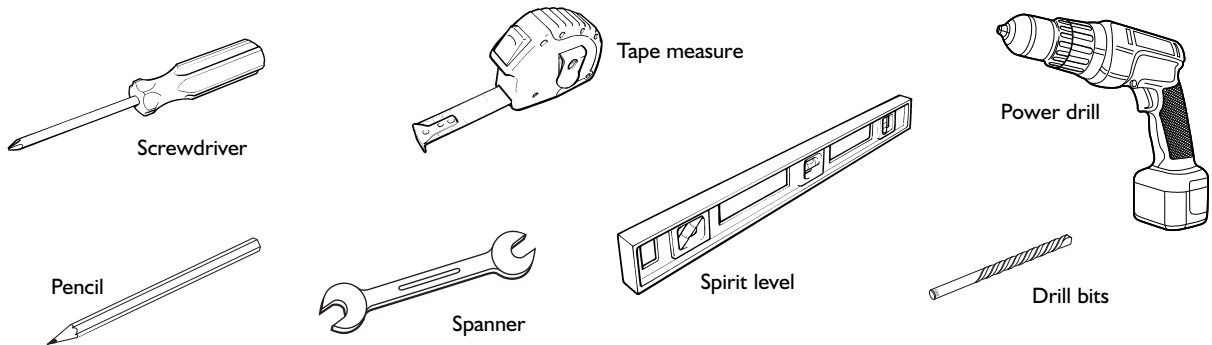

Contents of Kit

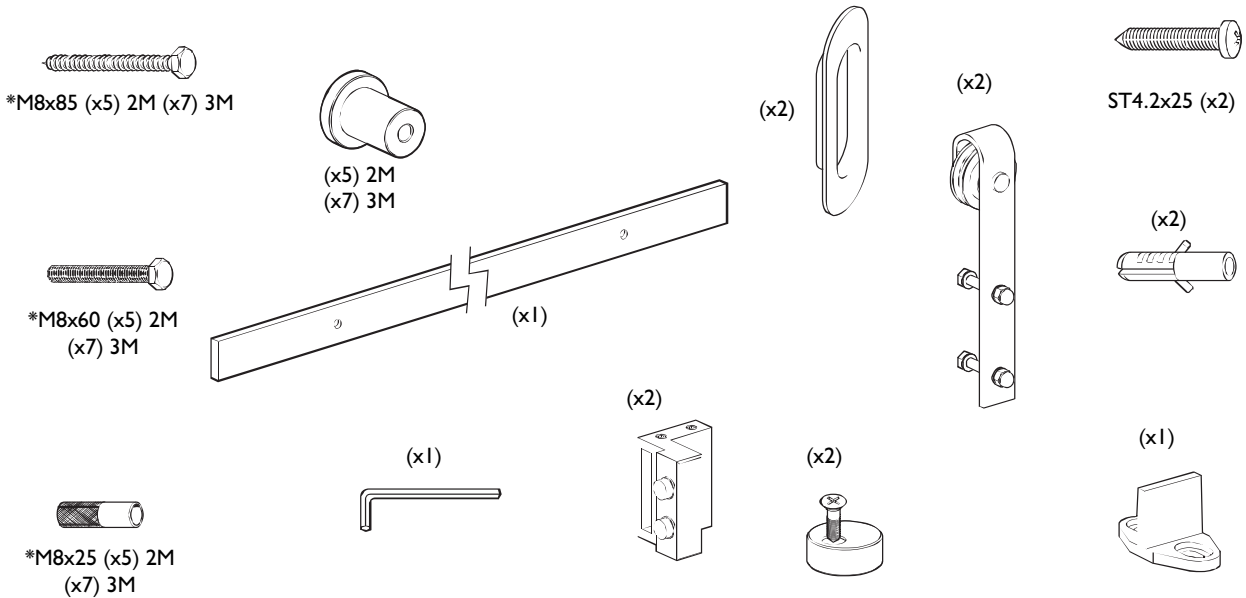

*Alternative track fixings provided - depending on wall type

I. Mark and drill fixing holes

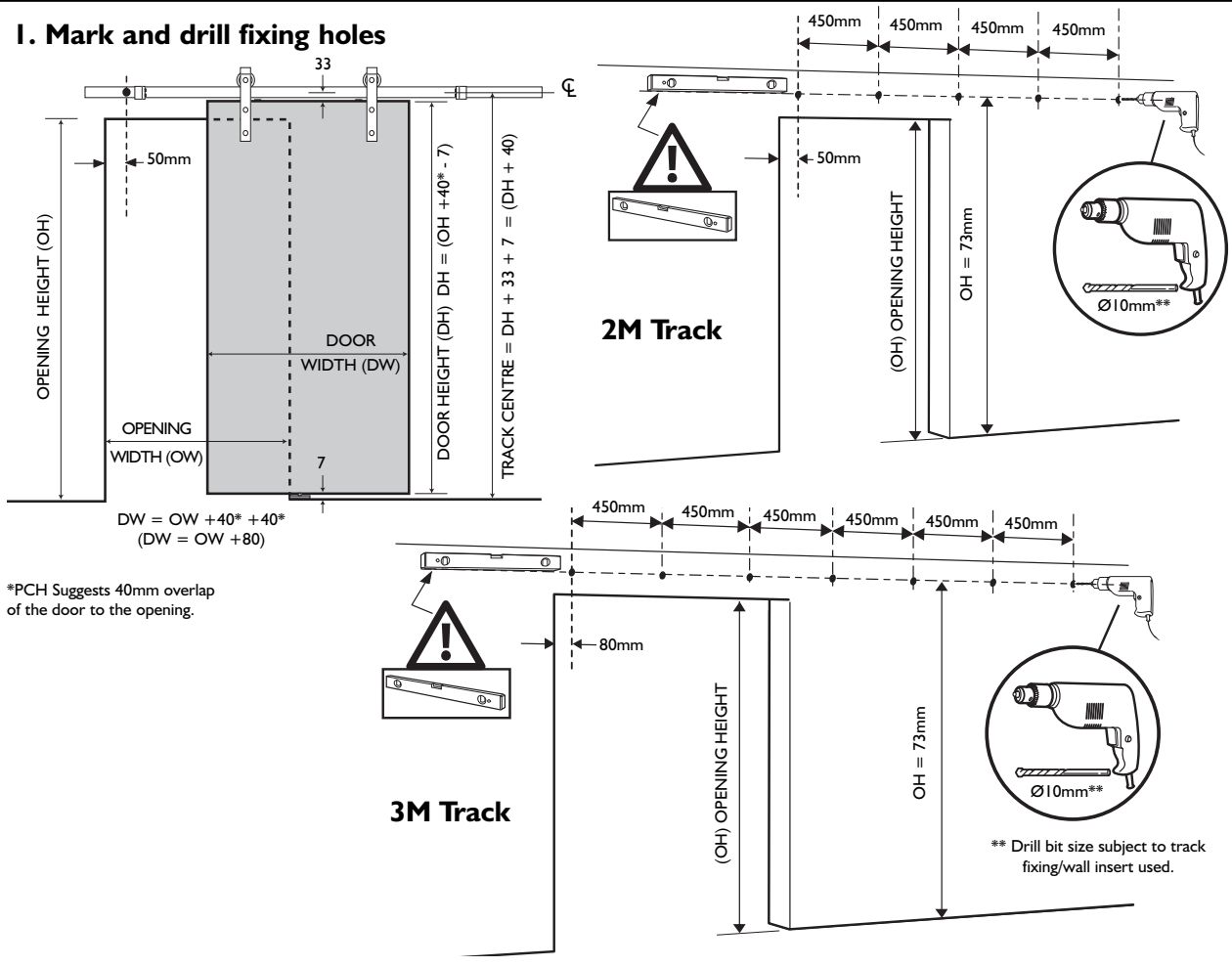

2. Fix M8 screw inserts, spacers and track to wall

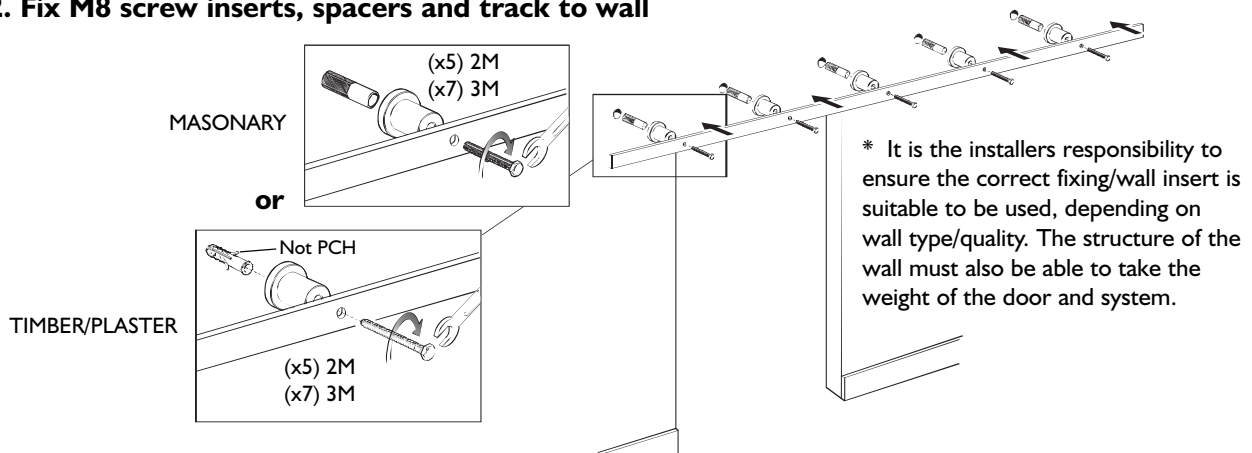

3. Fix hangers to door

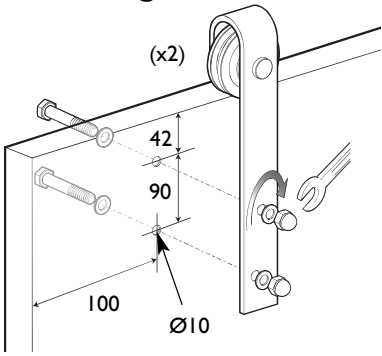

4. Floor guide routing detail

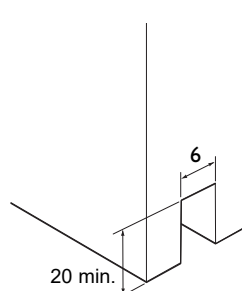

5. Fit anti-jump cams

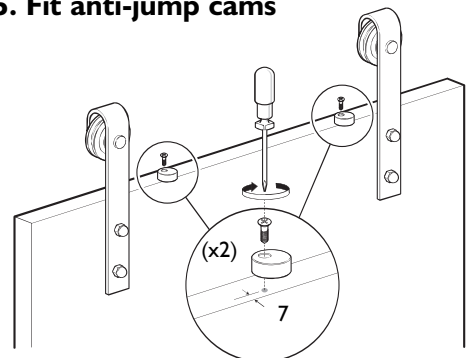

6. Hang door and adjust anti-just cams

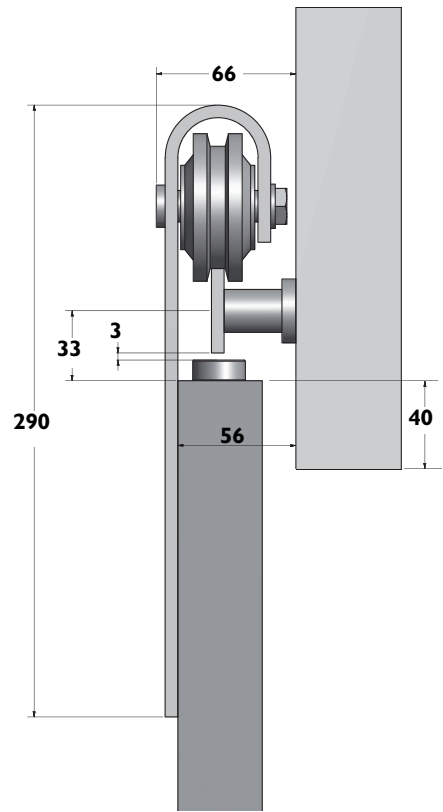
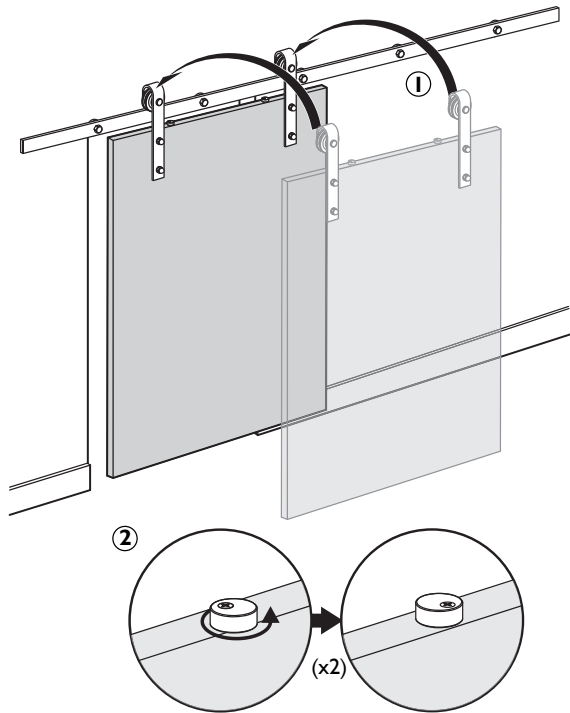

7. Fit floor guide

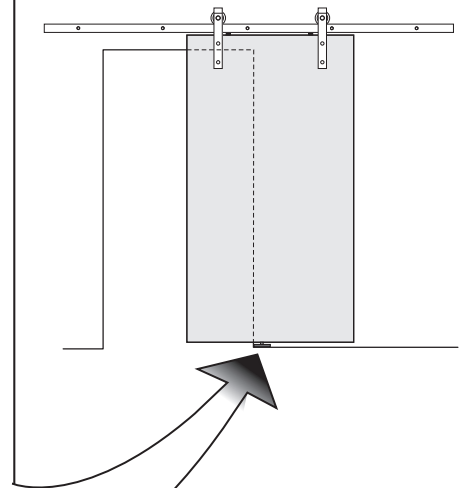
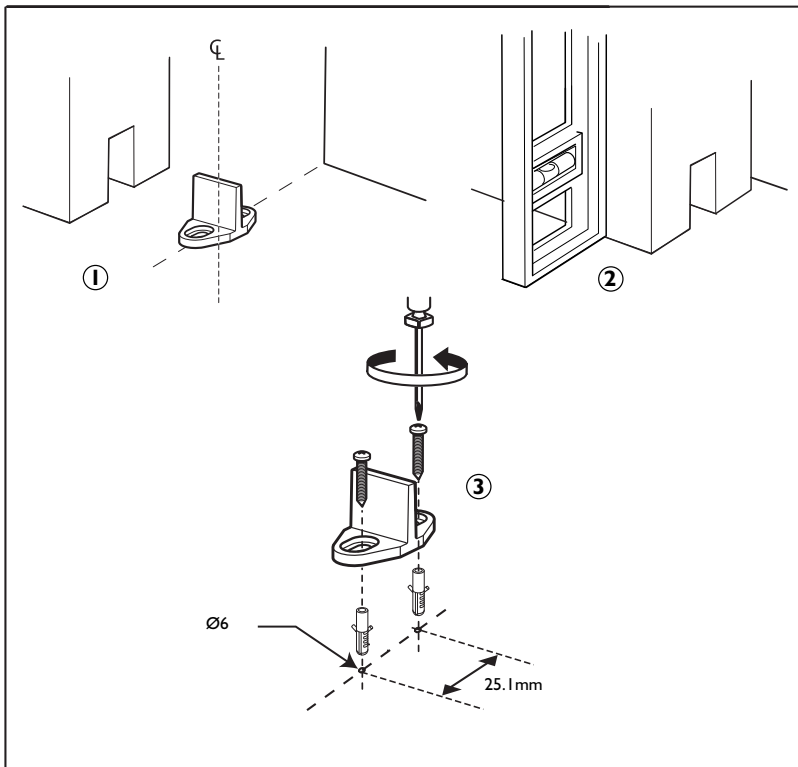

8. Fit and adjust door stops

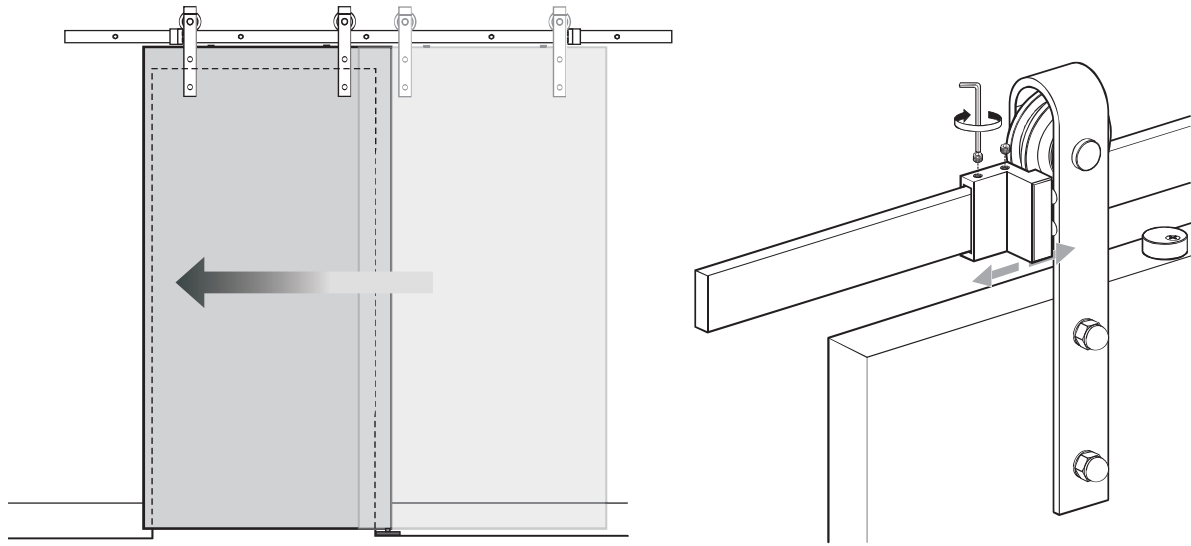

9. Flush pull handle routing detail

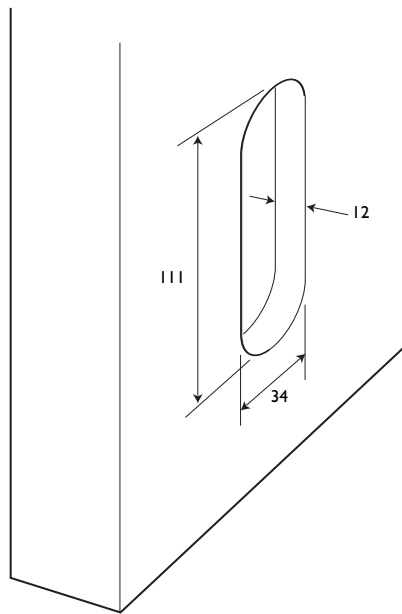

10. Fit flush pull handle

